

FINANCIAL ROADMAP: SCALING HIGH-TECH AQUACULTURE

Capital Requirements, Allocation
Strategy & Path to Profitability

Target: March 2027

CONFIDENTIAL / FINANCIAL OVERVIEW



THE OBJECTIVE: SOLVENCY THROUGH MARCH 2027

Peak Funding Requirement to bridge the "Valley of Death".

\$792 MILLION

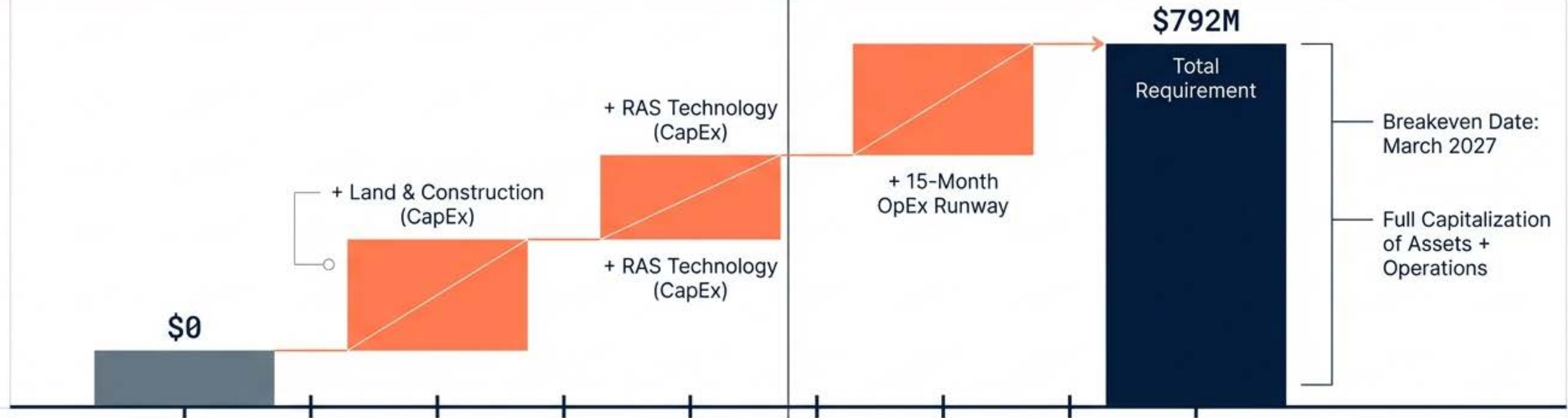

CAPITAL STRUCTURE STRATEGY

Minimizing Dilution via Asset-Backed Debt

DEBT TRANCHE

\$76 MILLION

- Secured against Tangible Assets
- Land, Building, & RAS Equipment
- Strategy: Match debt duration to asset life

EQUITY TRANCHE

\$716 MILLION

- Working Capital & Risk Buffer
- Covers 15-month operational burn
- Includes 15% contingency

We leverage long-term debt for infrastructure to preserve equity for the operational ramp-up.

CAPEX OVERVIEW: INFRASTRUCTURE DOMINATES RISK

90%+ of initial outlay is concentrated in fixed assets.



Insight: These costs lock in production capacity before a single dollar of revenue is generated. Construction and RAS procurement must happen in parallel.

\$45 MILLION TOTAL

\$15M Land Acquisition | \$30M Construction

JAN 2026

SEPT 2026



SITE PREP

Requires clear utility rights & water access verification. Includes 10% contingency.

BUDGET CONTROL

Mitigation: Lock fixed-price contracts early in 2025 to prevent overruns.

CRITICAL RISK

Completion past Sept 2026 **delays RAS install and incurs storage fees.**

THE ENGINE: RAS TECHNOLOGY

Biological life-support infrastructure.

\$12 MILLION



- ✓ Bio-Reactors & Filtration
- ✓ UV Sterilization Units
- ✓ High-efficiency Pumps
- ✓ Oxygenation Systems

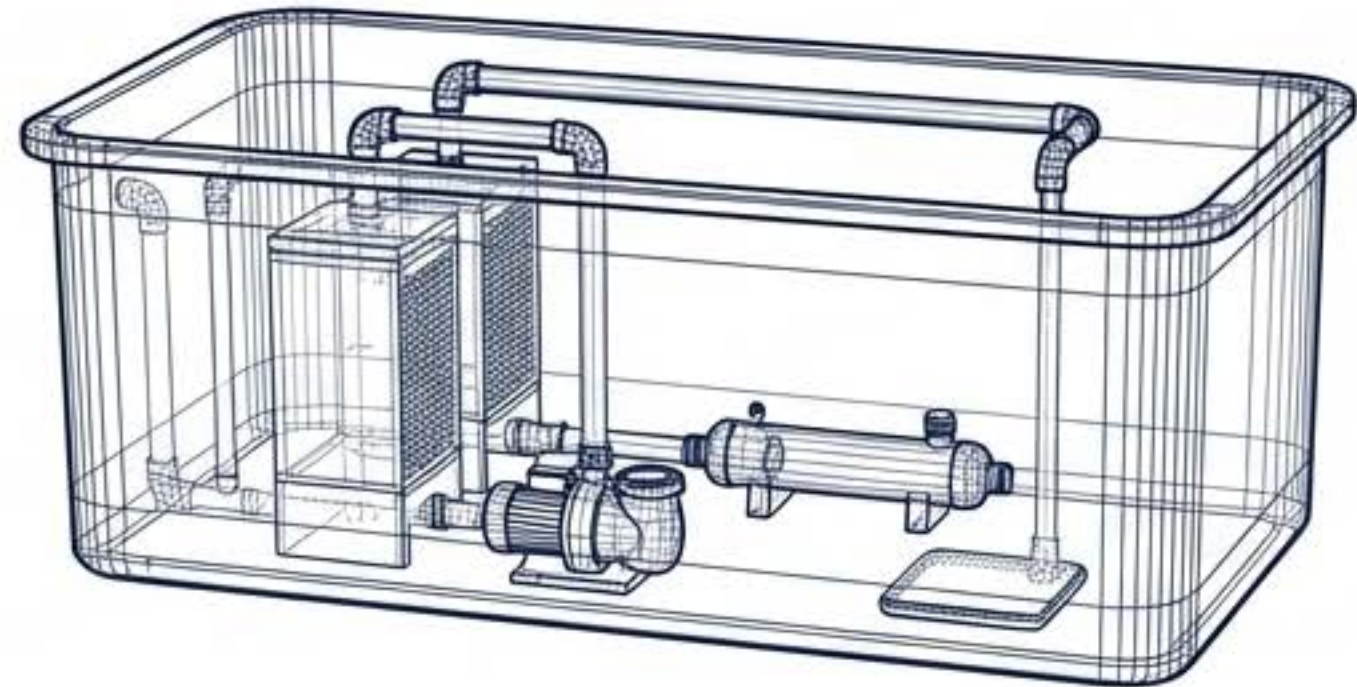

Procurement Strategy: Lock pricing by Q1 2026 to hedge against supply chain inflation. Modular design allows for scaling flow rates.

\$800,000 ALLOCATION



COMMODITY
(Whole Fish)

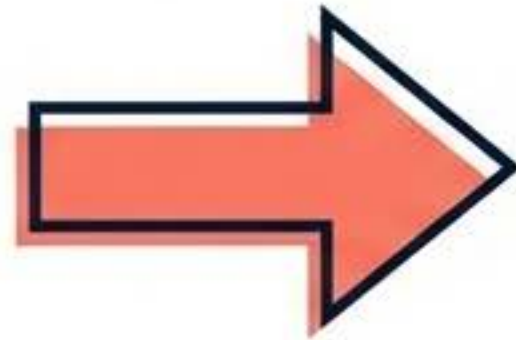

PREMIUM
(Fillets/Smoked)

Strategic Pivot: This minor investment unlocks premium consumer margins.

Equipment List

- Filleting Lines
- Vacuum Sealers
- Smoking Ovens

Tactic: Audit used market for certified gear to preserve cash. Do not over-spec capacity pre-revenue.

SURVIVING THE GAP: 15-MONTH RUNWAY

Modeling the 'Valley of Death' cash flow.

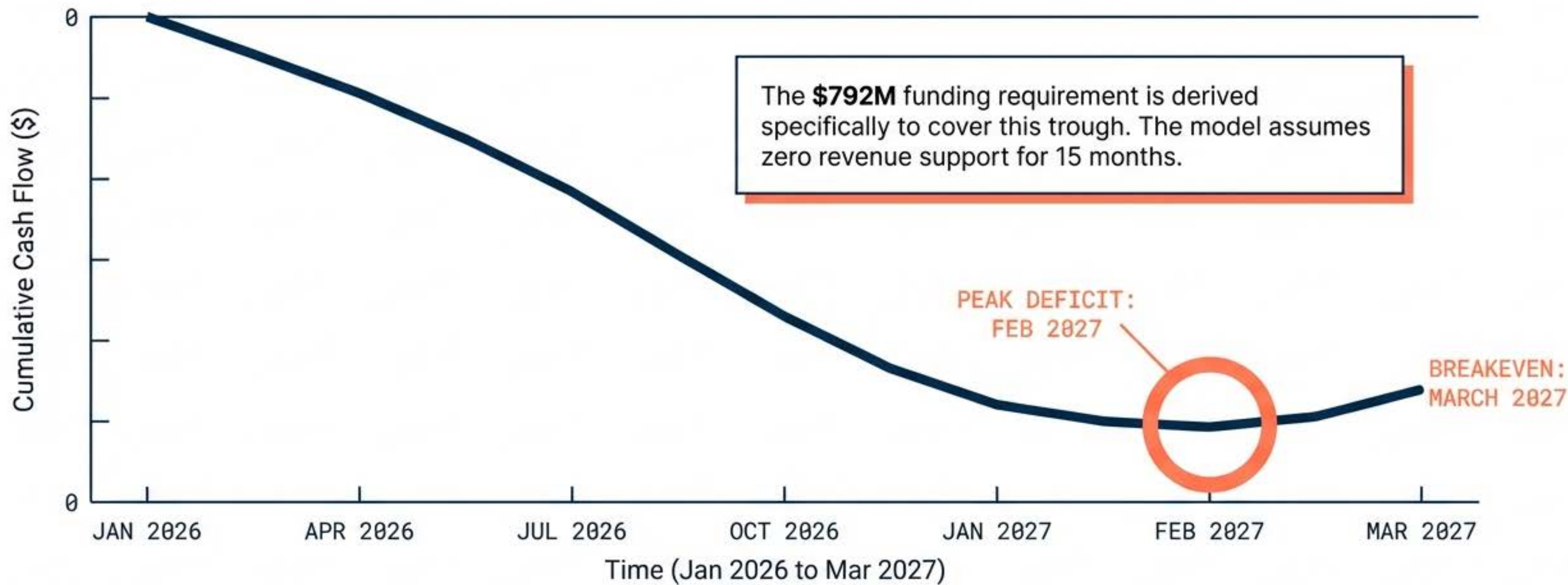

HUMAN CAPITAL: STAGGERED DEPLOYMENT

Runway Cost:
\$845,000 / Year

Monthly Burn:
~\$70,417

Headcount:
12 FTEs

Key Hires:
CEO (\$180k)
Lead Biologist (\$120k)

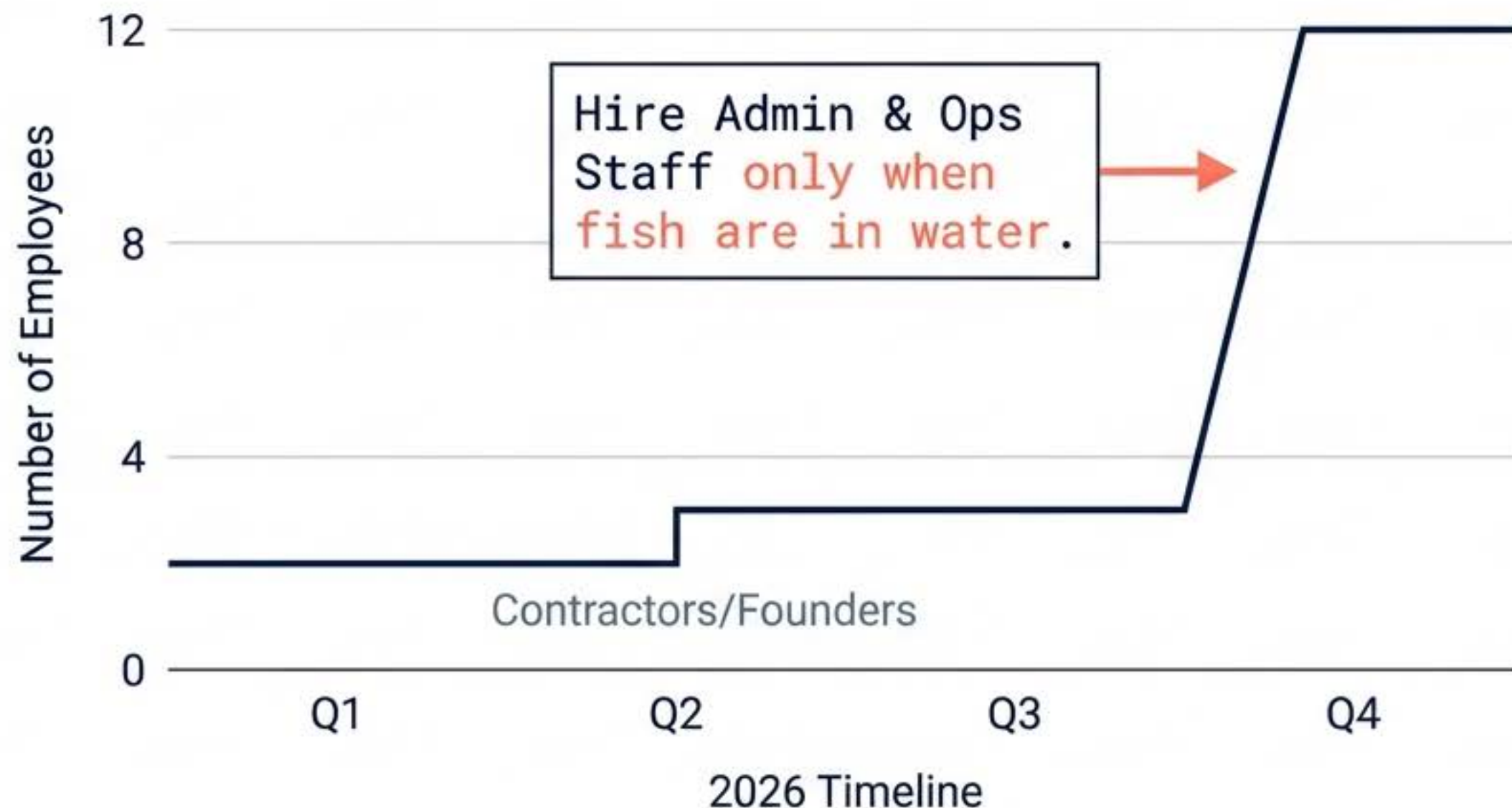

Strategic Implementation: Defer non-critical hires to preserve runway.

BIOLOGICAL ASSETS: THE CRITICAL PATH TO REVENUE

Low cost, high timing sensitivity.

\$150,000

INVESTMENT

(Broodstock & Juveniles)

Purchase Window:
Q4 2026 (Oct - Dec)

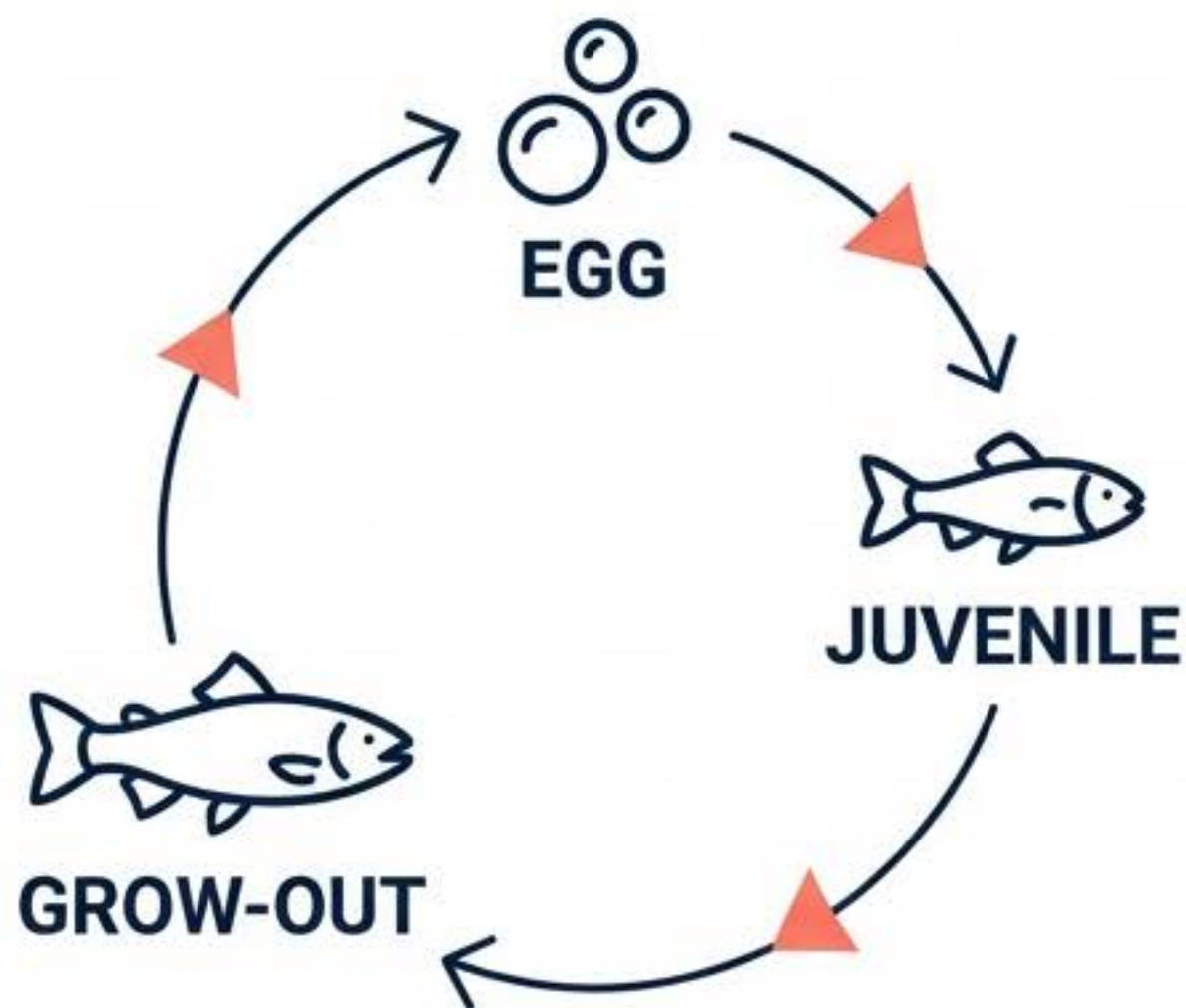

LOGISTICS CONSTRAINT:
Biological assets cannot be warehoused. The facility **MUST be ready** to receive stock.

REVENUE ACCELERATOR:
Shortening the grow-out cycle for this first batch **pulls the March 2027 breakeven date forward.**

FIXED OVERHEAD: THE BASELINE BURN

\$27,000 / MONTH

Non-Negotiable Cost of Existence

Facility Lease	Base Utilities	Insurance	Compliance
----------------	----------------	-----------	------------

THE COST OF DELAY

A 3-month launch delay burns an additional \$81,000 in pure overhead with zero offsetting revenue.

Optimization Strategy

1. Negotiate lease deferrals during construction.
2. Delay non-essential software procurement.

THE CRITICAL PATH: 2025 TO PROFITABILITY

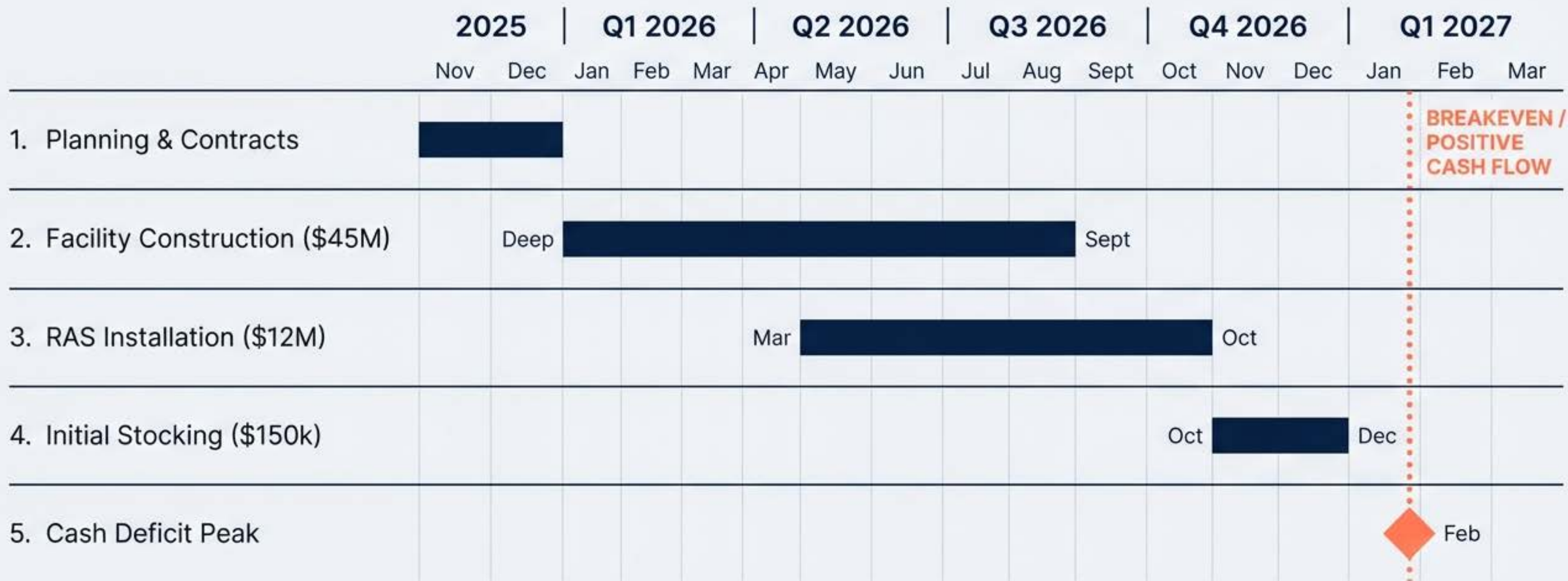

RISK MANAGEMENT MATRIX

CONSTRUCTION	Risk: Cost Overruns & Delays. Mitigation: Fixed-price contracts signed in 2025; 10% contingency buffer.
SUPPLY CHAIN	Risk: RAS Inflation. Mitigation: Lock components pricing in Q1 2026.
BIOLOGY	Risk: Stock Loss. Mitigation: Staggered hiring of specialists; excessive biosecurity protocols.
FINANCIAL	Risk: Liquidity Crisis. Mitigation: The \$792M funding target is calculated specifically to cover the Feb 2027 peak deficit.

INVESTMENT SUMMARY

FULLY FUNDED

\$792M requirement covers the peak deficit and 15-month runway.

ASSET BACKED

\$76M in hard assets (Land/RAS) capable of securing long-term debt.

DEFINED HORIZON

Clear path to confirmed **March 2027 breakeven.**

STATUS: READY

Land and utility rights verify-ready. **Capital deployment pending.**

